



(RESEARCH ARTICLE)



Observing the deepwater environment using an underwater vehicle

Mohammad Harun-Or-Rashid *, Abubakar Abdullah, Md. Ashikur Rahman, Aanha Haque and Md. Saber Hossain

Department of Mechanical and Production Engineering, Ahsanullah University of Science and Technology, Dhaka 1208, Bangladesh.

World Journal of Advanced Research and Reviews, 2024, 24(01), 706–719

Publication history: Received on 23 August 2024; revised on 05 October 2024; accepted on 07 October 2024

Article DOI: <https://doi.org/10.30574/wjarr.2024.24.1.2951>

Abstract

The development of a low-cost remotely controlled underwater vehicle, as well as wireless communication and submerging methods, are discussed in this paper. One of the major objectives of the present study was to monitor the underwater environment. An action camera was used to record the underwater environment. The shape of the underwater vehicle is cylindrical where radius and length are 0.15 m and 0.45 m respectively. SolidWorks software was used to design the vehicle and build it accordingly. For the main body, PVC pipe was used because it was cost-effective and wouldn't catch any rust. In the present study, it was found that radio frequency was not working properly underwater. Therefore, the antenna was extended above the surface of the water. Finally, experimental data was stored in a black box. From the experimental data, it is found that output responses like roll, pitch and yaw show good agreement against the input command.

Keywords: Ballast tank; Hull; Submarine; Unmanned underwater vehicle; Wireless communication

1. Introduction

An underwater remotely operated vehicle (UROV) is a type of watercraft that is designed to operate in water. It is operated by a human elsewhere from the system and used for various purposes such as detecting objects and rescue operations, and military, scientific, and commercial applications. In the present study, a camera is used for detecting the object. UROV operates by using a combination of mechanical and electrical systems. They can operate at various depths under the water's surface. In 1578, the initial conceptual design of a submarine was created [1]. From the Research of Mohammad Harun-Or-Rashid et al. [2], It has been seen that different components of the vehicle were made of Aluminum to reduce the weight and a Bluetooth module was used to receive the signal. From their paper, it was found that the setup was not perfectly water-protected. In the Research of Ricardo Perez-Alcocer et al. [3] it was discovered that even though GPS devices are widely used for localization, they show low performance in an underwater environment. Therefore, data fusion is needed to increase the accuracy of the position estimation. It has also been stated that underwater visibility is poor due to the optical properties of light propagation, absorption and scattering, which are involved in the image formation process. Kelasidi et al. [4] describe the cost of transportation using a dimensionless number, $CoT = \text{Energy} / (\text{Mass} \times \text{gravitational force} \times \text{Distance})$. It measures the amount of energy utilized to displace a designated mass over a certain distance. The cost of transportation has found diverse applications in determining the most energy-efficient movement of various systems. James C. Kinsey et al. [5], conducted research on navigation: determining the current position of a vehicle and choosing a collection of paths required to accomplish predetermined objectives.

Shahrieeel, Mohd Aras [6], describe the ballasting process of the submarine. This mechanical approach involves the use of pumps and compressed air to intake and release water. They found that using downward-facing thrusters as an

* Corresponding author: Mohammad Harun-Or-Rashid

alternative method which has several challenges and is not economically viable. On the other hand, Mohd Aras, Hazriq Izzuan Jaafar et al. [7] discussion about data acquisition. Data acquisition helps in accurately determining the submarine's position, speed, and heading. This information is crucial for navigation, especially in challenging underwater environments where global positioning system (GPS) signals may be limited or unavailable. Sumukha Udupa et al. [8] designed a robot that integrates manoeuvring capabilities, image recognition and depth control functionalities. The paper focuses on the design process of the robot and conducts simulation analysis to know its real-life performance. Software packages like SolidWorks and OpenProp are utilized for design and analysis purposes, while FlowExpress is employed for pressure and computational fluid dynamics (CFD) simulation. In the study of Leong Wai Lunn Alexander et al. [9] describe an autonomous underwater vehicle (AUV) that operates autonomously and performs predefined tasks. To accomplish the tasks of navigation and target acquisition, the AUV incorporates an autonomous guidance and control system. The AUV employs two thrusters for controlling horizontal movement, guided by a digital magnetic compass. Kalman filter algorithm is used to estimate the state of the navigation system. According to a research of MIT [10], sharing data between underwater and land-based environments poses challenges due to the use of distinct wireless signals optimized for each medium. Radio signals, effective in the air, lose strength rapidly in water, reducing their transmission range. Similarly, underwater devices relying on acoustic signals or sonar encounter difficulties as these signals primarily reflect off the water's surface and struggle to pass through it.

In the present study, the submerging was done by a ballasting process as mentioned in some of the previous works. Many of the researchers used thrusters to go either horizontally or vertically or even both and it needs much more energy and is not much cost efficient. Therefore, in this research, a peristaltic pump is used which requires less energy and less power. In this study, polyvinyl chloride (PVC) is used for the hull because of its lightweight and cheap. For controlling the system radio controller is used as it is much more responsive underwater compared to Bluetooth. This UROV is waterproof which is quite a challenge as many components are placed outside the body and the connection comes from inside. The ratio of diameter to length is 1:3 as it has less amount of radius compared to length; it needs less weight to submerge in the water. The main objective of this study was to build a low-cost (Total cost: 150 USD) UROV to monitor the underwater environment.

2. Steps of the Experimental process

The vehicle is controlled by an authority through the radio controller. Here, a camera is added to the vehicle. It can explore the underwater environment by using the recording option which enables more screening. The workflow diagram for the basic working of underwater vehicles:

- Step 1: Start the recording option of the camera to record the underwater environment.
- Step 2: Put the vehicle on the surface of the water.
- Step 3: Start the pump to intake the water into the ballast tank. The vehicle continues to sink as it fills.
- Step 4: Start the BLDC motor to move the vehicle forward.
- Step 5: Use the servo motor to turn the UROV left or right.
- Step 6: Run the vehicle under the water and record the environment as well as save the roll, pitch and yaw data in the SD card.
- Step 7: After a few minutes start the pump again to exhaust the water from the ballast tank. The vehicle continues to rise as it empties.

3. UROV Dynamics

UROVs are used extensively in marine exploration, underwater inspections, and scientific research. One of the key components of a UROV is its propulsion system, which is responsible for providing the necessary thrust to overcome the drag and friction forces that act on the vehicle as it moves through the water. In most cases, UROVs use motors for propulsion due to their low cost and ease of maintenance. The amount of thrust produced by the propulsion system is directly related to the amount of drag experienced by the vehicle. This relationship can be expressed mathematically using Eq. (1).

$$T_p = \frac{C_d \rho A s^2}{2} \quad (1)$$

where ρ is the density of the water, s is the speed, A is the effective surface area of the vehicle, and C_d is the drag coefficient. The effective surface area is the surface area of the vehicle that is in contact with the water and is perpendicular to the direction of motion. The effective surface area of the UROV is an important consideration when

calculating the amount of drag experienced by the vehicle. The drag coefficient of the UROV is another critical factor in the calculation of drag. The drag coefficient is a dimensionless quantity that characterizes the resistance of an object to motion through a fluid. It is influenced by the shape, size, and orientation of the object, as well as the properties of the fluid. As the UROV moves through the water, it experiences a variety of forces, including drag and friction forces. These forces act to slow down the vehicle and require a certain amount of thrust to overcome. The amount of thrust required to move the UROV through the water is directly related to the speed of the vehicle. As the speed of the UROV increases, the drag and friction forces also increase, requiring a larger amount of thrust to overcome.

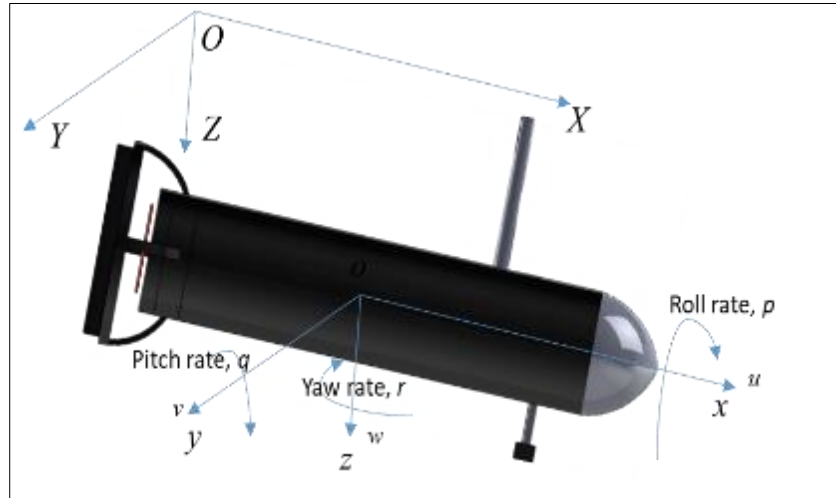

Figure 1 Linear and angular velocity of the UROV

Engineering mechanics generally consider six degrees of freedom (DoF) for a rigid body. Three are translational degrees of freedom and the others are rotational degrees of freedom. Movement of the UROV is shown in Fig.1. In hull-fixed reference axes systems, Newton-Euler equations of motion [Eq. (2)-Eq. (7)] are as follows:

$$\dot{X} = u \cos \theta \cos \psi + v (\sin \phi \sin \theta \cos \psi - \sin \psi \cos \theta) + w (\cos \phi \cos \psi \sin \theta + \sin \phi \sin \psi) \quad (2)$$

$$\dot{Y} = u \cos \theta \sin \psi + v (\sin \phi \sin \theta \sin \psi + \cos \phi \cos \psi) + w (\cos \phi \sin \theta \sin \psi - \sin \phi \cos \psi) \quad (3)$$

$$\dot{Z} = -u \sin \theta + v \sin \phi \cos \theta + w \cos \phi \cos \theta \quad (4)$$

$$\dot{\phi} = p + q (\sin \phi \tan \theta) + r (\cos \phi \tan \theta) \quad (5)$$

$$\dot{\theta} = q \cos \phi - r \sin \phi \quad (6)$$

$$\dot{\psi} = q (\sin \phi / \cos \theta) + r (\cos \phi / \cos \theta) \quad (7)$$

Here, u , v , w are linear velocities, and p , q , r are angular velocities of the submarine. On the other hand, ϕ , θ , and ψ are the roll, pitch and yaw rotation respectively.

4. 3D Modelling and Constructing of the UROV

The CAD model of the underwater vehicle is presented in Fig.2. Design is done in SolidWorks. The main parts of the body are the outer hull made of PVC pipe, one ballast tank placed inside of the hull, a rear frame for attaching the servo motor and the rudder mechanism. The frame is also very useful for human safety because the propeller rotates very high RPM. Furthermore, an antenna and a camera are attached to the hull. All technical specifications of the UROV are presented in Table 1.

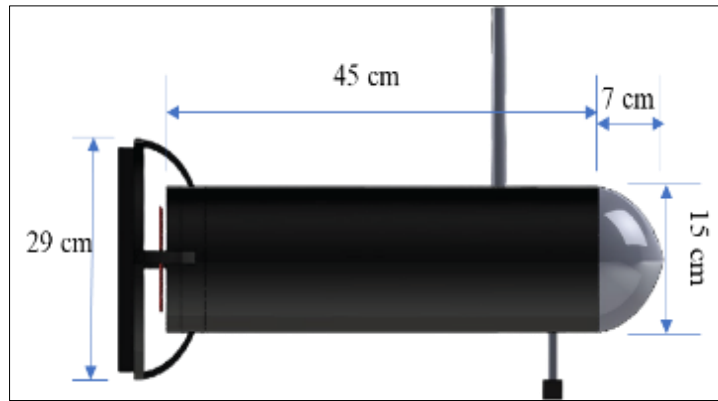

Figure 2 SolidWorks design of the UROV

Table 1 Technical Specifications of the UROV

| Parameter | Value |
|--|-----------------------------------|
| Maximum speed | 0.243 m/s |
| Dimension | |
| Total Length | 65 cm |
| Length of main vessel | 45 cm |
| Diameter of Main vessel | 15 cm |
| Length of front | 7 cm |
| Length of rear part | 13 cm |
| Weight | |
| Designed body | 7.95 kg |
| Actual body | 7.8 kg |
| With water mass balance | 10 kg (max.) |
| Power System | |
| Voltage | 11.1 V |
| Current | 2.2 A |
| Capacity | 24.4 Wh |
| Antenna | |
| Extended pipe length for antenna | 70 cm |
| Diameter of the pipe used for the protection of the antenna wire | 1.5cm |
| Control System | Wireless control via Arduino Mega |
| Propulsion System | Brushless DC motor |

For an object to sink, it has to have more density than water. Therefore, letting the water get into the ballast tank which increases the density of the object and on the other hand, keeps the volume constant. The volume of a cylindrical main hull is calculated by the Eq. (8).

$$V = \frac{\pi D^2 L}{4} \quad (8)$$

Here, the length of the hull is L and the diameter of the hull is D. It is known that volume is proportional to the required mass ($V = \frac{m}{\rho}$) for the object to sink, therefore, to do that it is important to minimize the volume to reduce the mass requirement as the motor which is being used is not capable of moving a huge load. Since density is constant (density, ρ of water is 1000 kg/m^3), length is in simple form and diameter is in squared form, if the diameter remains small and the length increases it won't have as much volume as it would have been used in bigger diameter.

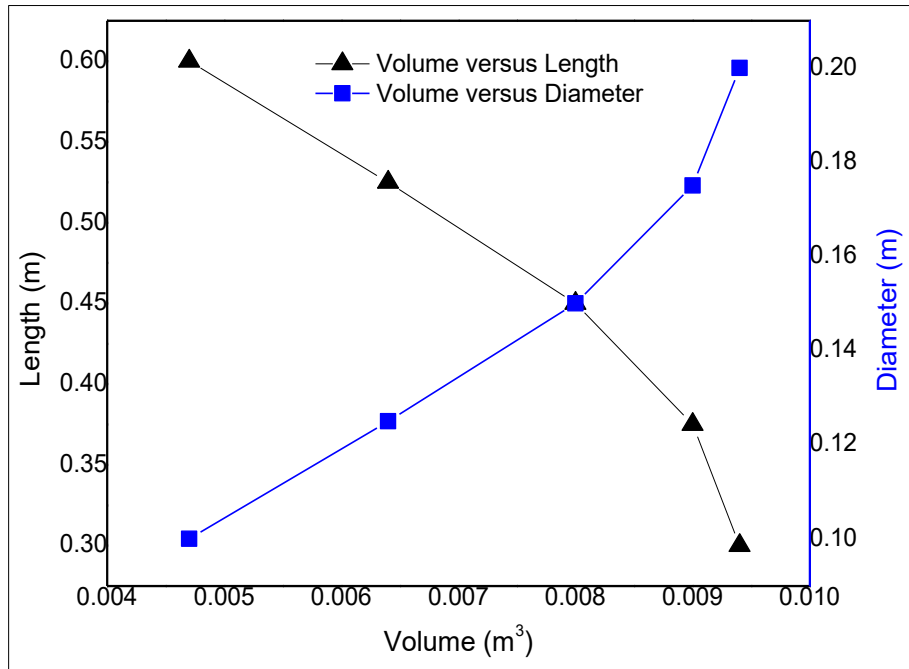

Figure 3 Change of volume with the change of length and diameter of the hull

In Fig. 3 length and diameter of the hull are changed simultaneously. Finally, 0.008 m^3 volume is selected where the length is 0.45 m diameter is 0.15 m . In this optimum condition, the vehicle starts to sink if the ballast tank is filled with water.

The total mass of the body is 7.8 kg while the ballast tank is empty. During the experiment, it is found that when the ballast tank is partially filled with water and the mass becomes 8 kg then the submarine starts to submerge.

Finally, a small unmanned submarine is constructed according to the estimated parameters and presented in Fig. 4. In the present study, two different models of the main body are developed using two different materials: one is made of PVC pipe (Fig. 4) and another is made of Acrylic sheet. A 0.254 m propeller is used to convert motor power into thrust. It can generate sufficient force to propel the submarine through the water.

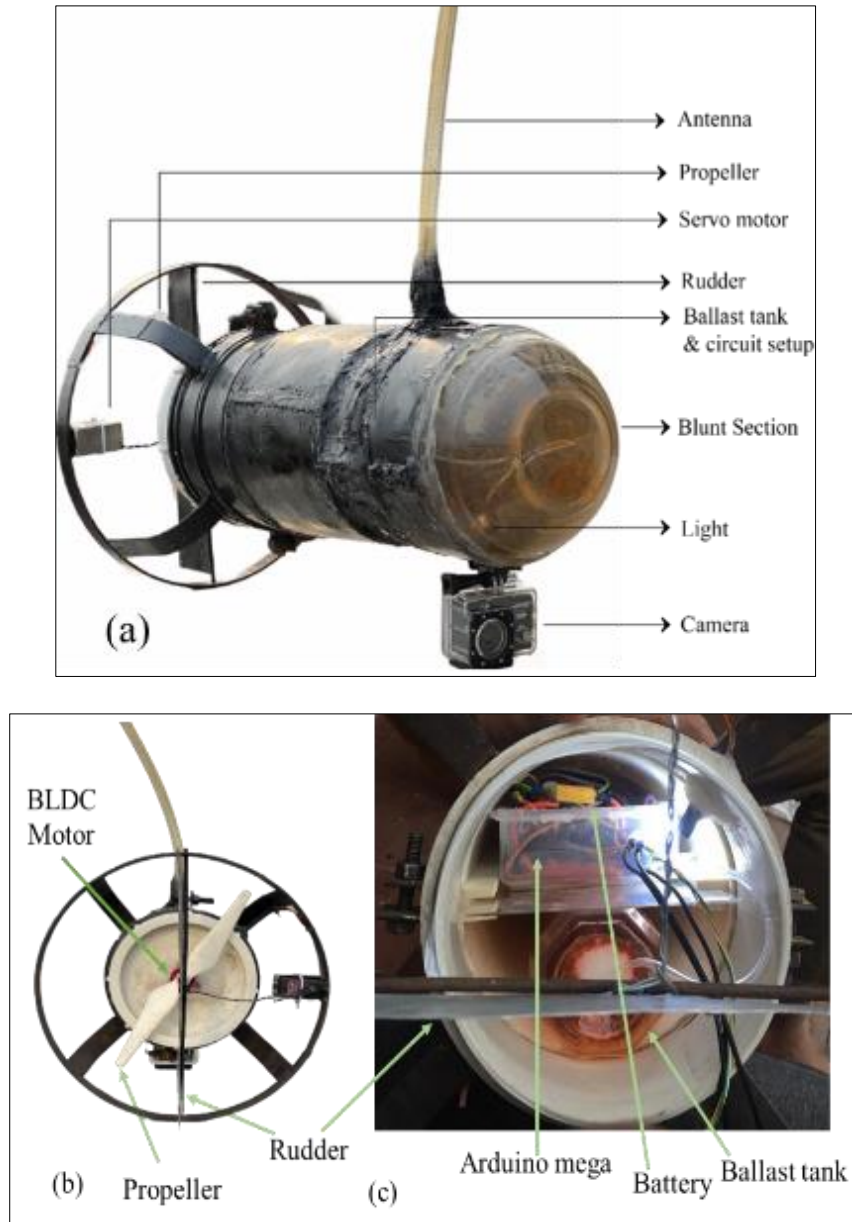

Figure 4 Under water vehicle: (a) Isometric view, (b) Back view, (c) Front view: Position of the ballast tank and the electric circuit

4.1. Comparison between Acrylic and PVC hull

At first, Acrylic was selected for the main body of the submarine because it is transparent. Therefore, one or more cameras can be placed at any position inside the vehicle and can observe the underwater environment easily.

During the construction of the acrylic body, the acrylic sheet was heated to make it pliable and then bent into the desired shape of a round cylinder. Two caps were added to the body that could be opened and closed as needed.

The problem of the Acrylic material is that, it is prone to brittleness and may break under high pressure, especially when it is exposed to water for extended periods. It became apparent that Acrylic was not suitable for this application as it could not withstand the torque generated by the BLDC motor, and the Acrylic joints weakened the structural integrity of the device. Furthermore, during the experiment, water leakage was found at different joints.

Therefore, after facing these problems Acrylic hull was replaced with the PVC hull because PVC is a more flexible and durable material that can better withstand underwater pressure compared to Acrylic.

In summary, the initial choice of using acrylic for the device's body proved to be unsuitable due to its poor withstanding quality, weakened structural integrity and water leakage at the joints. PVC pipe was subsequently used, and it proved to be a better option as it could handle the torque and pressure of the water and prevent water leakage.

4.2. Description of the Electrical Components

A 16-bit microcontroller board (Fig. 5) that is based on the ATmega2560 chipset is used in this study. I/O pins, communication interfaces, expandability, and compatibility with libraries make it a suitable choice for electro-mechanical projects. It provides the necessary features and resources to facilitate the integration and control of various radio frequency modules, enabling to build of wireless communication systems, remote control applications and sensor networks. An SD card module is connected to this board to save the experimental data in real-time.



Figure 5 Arduino Mega 2560 R3



Figure 6 Brushless DC Motor (920KV)

A brushless DC motor (Fig. 6), also known as a BLDC motor, is an electric motor that does not require physical brushes to transfer power to the motor's rotor. Instead, the motor uses electronic commutation to control the flow of electricity and generate torque. The BLDC motor model A2212/6T with a KV rating of 920 was used for rotating the propeller. This motor is a popular choice among professionals due to its high efficiency, low maintenance requirements, and long lifespan.



Figure 7 Electronic Speed Controller

The Electronic Speed Controller (ESC) of 30 A shown in Fig. 7 is used in the field of radio-controlled (RC) vehicles to control the speed of the electric motor. The ESC takes the signal from the microcontroller board and sent to the motor. ESCs are commonly used with brushless motors due to their high efficiency and performance characteristics.



Figure 8 SG90 Mini Servo Motor

The SG90 Mini Servo Motor (Fig. 8) is designed to operate with DC power. The SG90 Mini Servo Motor offers precise control and positioning capabilities. It can rotate within a specific angle range and hold positions accurately. This precision is valuable in submarine applications that require precise control of movable parts, such as the rudder.



Figure 9 A 12V Peristaltic dosing pump with Silicone tubing

A peristaltic dosing pump (Fig. 9) is a type of pump that utilizes a squeezing motion to move water through a tube to the ballast tank and remove from it. The peristaltic dosing pump model being referred to operates at 12 volts and uses silicone tubing for fluid transfer. The specifications of this peristaltic dosing pump include a maximum flow rate of 90 ml/minute, a maximum suction lift of 2 meters, and a maximum discharge head of 3 meters. It has a motor speed of 3000 RPM and a motor power consumption of 4.5 watts. This pump can both intake water at one side and exert the same water on another side.



Figure 10 A 2200mAh Li-Po Battery

A 2200mAh 3S Li-Po Battery (Fig. 10) is used for power supply to the whole UROV. It is used to support all the equipment like the pump, brushless motor, servo motor and microcontroller board. It offers a high energy density compared to other batteries. This means that they can store a significant amount of energy in a compact and lightweight package. In a small submarine, where weight and space are critical factors, the high energy density of this battery allows more power storage without sacrificing valuable space.

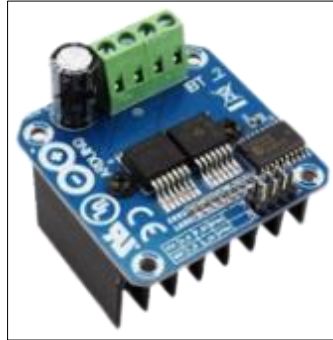

Figure 11 Motor Driver, BTS7960

During the selection of a motor driver, it is important to ensure that the motor driver is properly rated and matched with the specific motor requirements to ensure optimal performance and prevent damage. A 43A BTS7960 motor driver shown in Fig11 is used in this research because of its high current handling, dual H-bridge configuration, PWM speed control, thermal protection and compatibility with the microcontroller board.

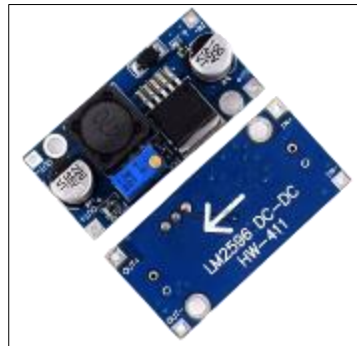

Figure 12 LM2596 DC-DC step-down power supply module

The LM2596 DC-DC buck converter (Fig.12) is an electronic module that converts a higher-voltage DC input to a lower-voltage DC output. The module is designed to operate with input voltage in the range of 4.5V to 40V and output voltage in the range of 3V to 35V.

A FlySky FS-i6 2.4G transmitter is used to send the signal to the FS-iA6 receiver in the vehicle. The user manipulates the command signal on the remote, such as the throttle, and steering to control the vehicle's movements.

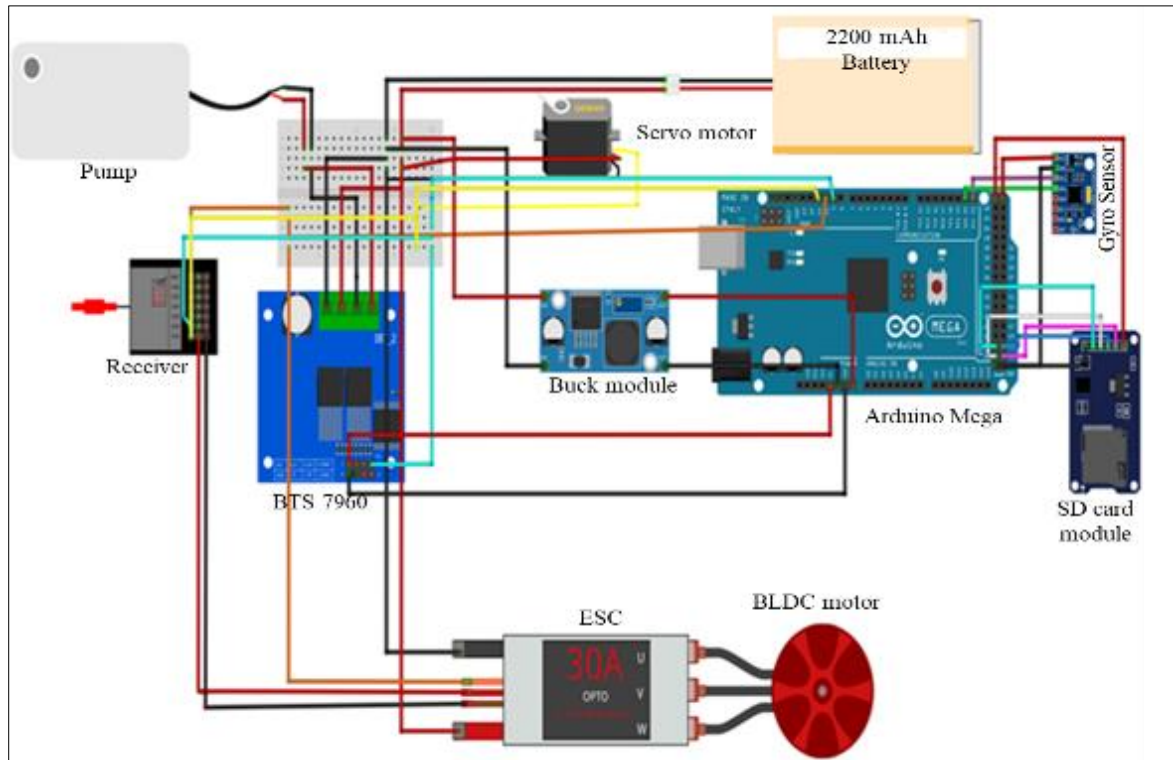

Figure 13 Electric circuit

The connection of different electric components is presented in Fig.13. In this setup the Arduino microcontroller board is being used to control the water pump through the BTS7960 motor driver that is BTS7960 motor driver is connected with the Arduino board. A receiver is connected to the board to receive the commands from the transmitter and save the data on the SD card. The receiver signal directly goes to the servo motor to set the submarine's heading left or right direction as well as it goes to the controller to save it. The ESC is a device that is used to control the speed of the BLDC motor, often used in remote-controlled vehicles or drones. The power for the ESC is provided by a battery. The signal from the receiver goes to the BLDC motor through the ESC. This receiver signal also goes to the microcontroller board to save it.

5. Result and Discussion

Fig. 14 shows the input command generated from the transmitter for the BLDC motor. This motor rotates the propeller and gives a forward motion of the UROV. This kind of doublet shape command is very useful for investigating the output response of the system. If the command increases then the propeller RPM as well as the speed of the UROV increases. It also affects the rolling motion of the system. From Fig. 15 it is seen that if the propeller RPM increases then the roll angle also increases this is because the propeller produces torque. Due to this torque system starts to rotate around the *x*-axis. At the same time, propeller rotation also affects the pitching motion which is shown in Fig. 16.

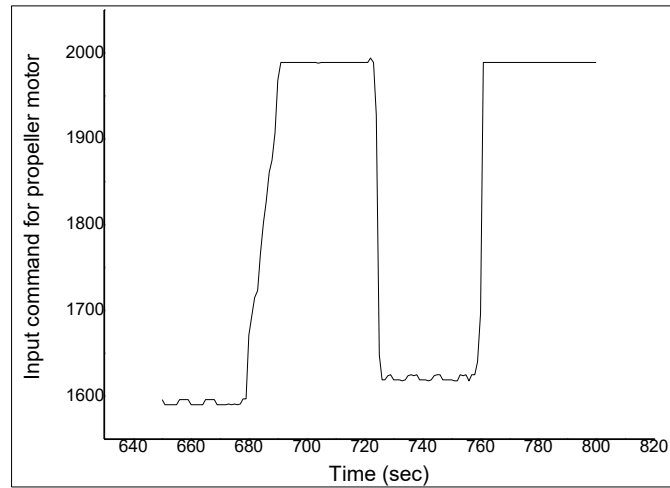

Figure 14 Input command for the BLDC motor

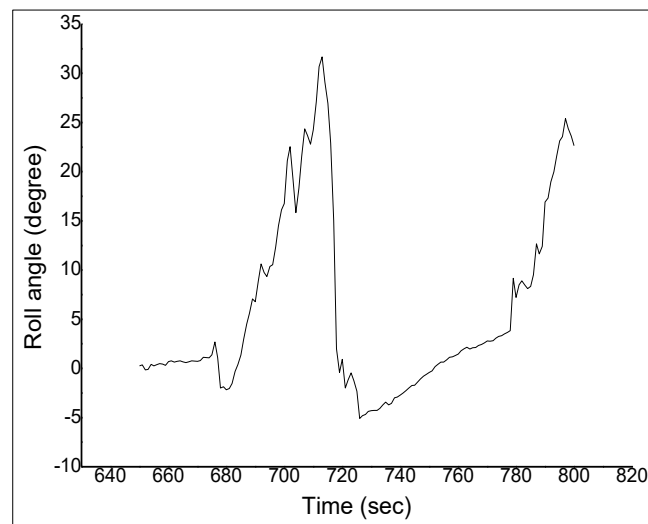

Figure 15 Roll response of the UROV

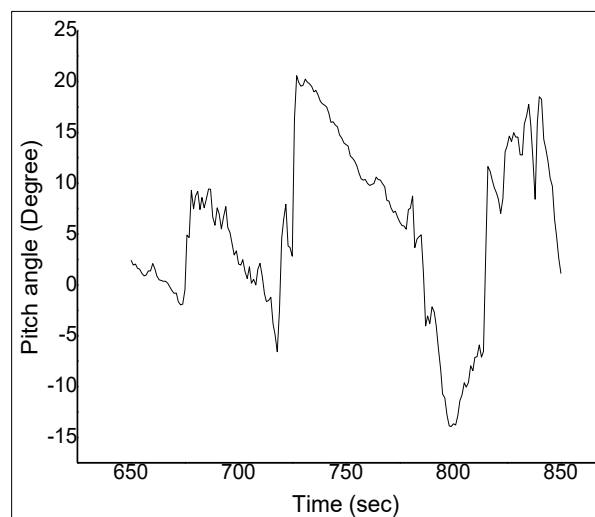

Figure 16 Pitch response of the UROV

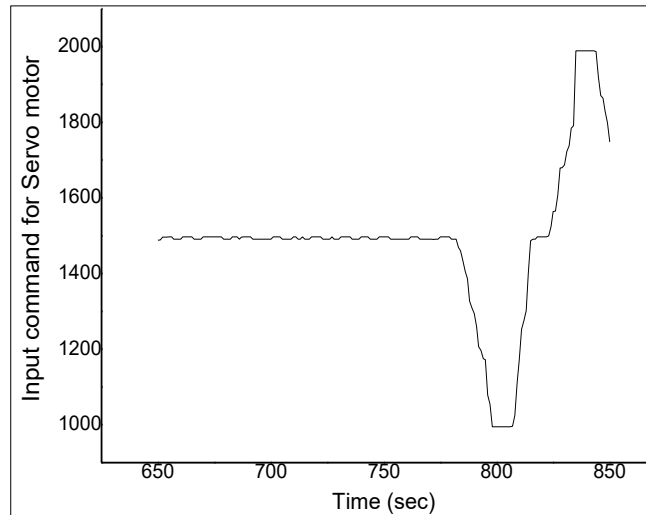

Figure 17 Input command for the rudder

To control the rudder a waterproof servo motor is used. The input command for the servo motor is presented in Fig. 17. This command is generated by the transmitter. After sending the command to the servo motor the rudder starts to rotate and as a result heading of the UROV changes. The output response of the system is shown in Fig. 18. From this figure it is found that, yaw angle is changes according to the command of the rudder.

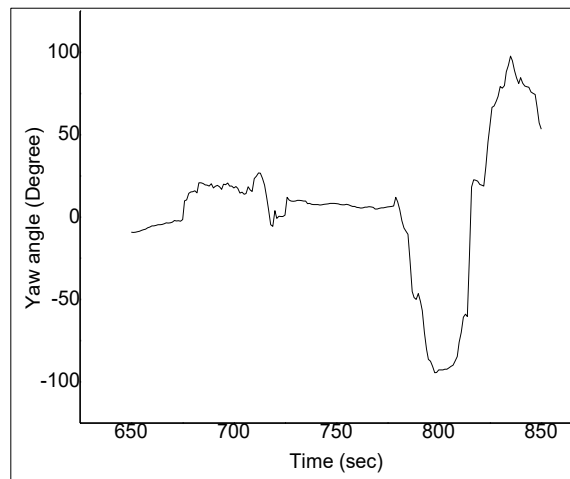

Figure 18 Yaw response of the UROV



Figure 19 Underwater environment captured by the camera

In the present study, a waterproof camera is attached to the outside of the system and a light is used inside of the system to monitor the underwater environment. The camera can record the video file as well. A picture of the underwater environment is shown in Fig. 19. Higher resolution camera as well as higher light intensity can improve the visibility of the underwater environment.

Nomenclature

$\dot{X}, \dot{Y}, \dot{Z}$: Linear velocities in fixed reference frame (m/s)

u, v, w : Linear velocities in the object reference frame (m/s)

$\dot{\phi}, \dot{\theta}, \dot{\psi}$: Angular velocities (rad/s)

m : mass (kg)

ρ : Density of the water (kg/m³)

L : Hull length (m)

D : Hull diameter (m)

List of abbreviations

AUV: Autonomous underwater vehicle

CFD: Computational fluid dynamics

GPS: Global positioning system

PVC: Polyvinyl chloride

UROV: Unmanned remotely operated vehicle

6. Conclusion

The goal of this research was to develop a battery-powered low-cost underwater vehicle where no fuel is required to monitor the underwater environment. The efficiency of the vehicle largely depends on the proper transmission system, load, shape and the design of the propeller. The underwater vehicle was successfully made and the making process of this vehicle is mentioned in this paper. In this study, one of the major concerns was wireless communication. It was solved by using a long antenna. The basic use of the unmanned underwater vehicle is to observe the underwater environment. With the help of the camera and image processing, it can be found any desirable object. A camera is attached to the UROV which can video an underwater environment and save the file in its memory. As it is operated from a distance without a living soul in the vehicle, therefore, the risk of the loss of human's life is decreased in the war and uneven situation. This underwater vehicle is able to inspect the submerged pipelines that are used to transfer crude oil and communication cables. Furthermore, it can collect data and can be used for port and harbor security tasks.

Compliance with ethical standards

Acknowledgments

Thanks to Ahsanullah University of Science and Technology, 141-142 Love Road, Tejgaon, Dhaka 1208, Bangladesh.

Disclosure of conflict of interest

No conflict of interest to be disclosed.

References

- [1] Budiyo, A. (2009). Advances in Unmanned Underwater Vehicles Technologies: Modeling, Control and Guidance, Perspectives. Indian Journal of Marine Sciences, Vol.38, pp282-295.
- [2] Rashid, M.H.O and Bishwas, D. (2019). Fabrication and Study of An Unmanned Under Water Vehicle. IOSR Journal of Mechanical and Civil Engineering, Vol.16 No.2, pp.5461.
- [3] Pérez-Alcocer, R., Torres-Méndez, L.A., Olguín-Díaz, E. and Maldonado-Ramírez, A.A. (2016). Vision-Based Autonomous Underwater Vehicle Navigation in Poor Visibility Conditions Using a Model-Free Robust Control. Journal of Sensors, Vol.2016, pp.1-16.

- [4] Kelasidi,E., Pettersen, K.Y., Gravdahl, J.T. (2015). Energy efficiency of underwater robots. IFAC (International Federation of Automatic Control), Trondheim, Norway, pp.152-159.
- [5] Kinsey, J.C., Eustice,R.M., Whitcomb,L.L.,(2006). A SURVEY OF UNDERWATER VEHICLE NAVIGATION: RECENT ADVANCES AND NEW CHALLENGES. The Johns Hopkins University, Baltimore, Maryland USA.
- [6] Aras,M.S.M, Kasdirin, H.A., Jamaluddin, M.H., Basar, M.F., Elektrik,F.K., (2009). Design and Development of an Autonomous Underwater Vehicle (AUV-FKEUTeM). Proceedings of MUCEET2009 Malaysian Technical Universities Conference on Engineering and Technology, MUCEET2009, MS Garden, Kuantan, Pahang, Malaysia.
- [7] Aras, M.S.M, Abdullah, S.S., Rahman, A.F.N.A,Basar, M.F,Kassim,A.M. and Jaafar,H.I., (2015). Analysis of movement for unmanned underwater vehicle using a low cost integrated sensor. American Institute of Physics, International Conference on Mathematics, Engineering and Industrial Applications, Penang, Malaysia, pp.70052.
- [8] Udupa, S., Joshi, N., Raman,S., (2017). Design, analysis and control of an autonomous underwater surveillance robot. 2017 IEEE International Conference on Consumer Electronics-Asia (ICCE-Asia), R.V. College of Engineering Bengaluru, Karnataka, India, pp. 121-126.
- [9] Alexander,L.W.L., Roslan, M.M.A., Isa,K., Kadir,H.A. and Ambar,R., (2018). Design and Development of an Autonomous Underwater Vehicle (AUV) with Target Acquisition Mission Module. 2018 IEEE 8th International Conference on Underwater System Technology: Theory and Applications (USYS), Universiti Tun Hussein Onn Malaysia (UTHM) 86400 Parit Raja, Batu Pahat, Johor, Malaysia, pp.1-6.
- [10] Matheson, R. (2018). Wireless communication breaks through water-air barrier. MIT News. Available at: <https://news.mit.edu/2018/wireless-communication-through-water-air-0822>.
- [11] Kumar, S.,Mohammad, S.,Bora, S. and Singh, M.(2015). A Review Paper on: Autonomous Underwater Vehicle. International Journal of Scientific & Engineering Research, Vol.6, pp 38-40.
- [12] Wang, W.H.,Chen, X.Q.,Marburg A.,Chase J.G. and Hann, C.E.(2009). Design of Low-Cost Unmanned Underwater Vehicle for Shallow Waters. International Journal of Advanced Mechatronic Systems, Vol.1, No.3, pp.194–202.
- [13] Button, RW., Kamp, J., Curtin, TB. and Dryden, J. (2009). A Survey of Missions for Unmanned Undersea Vehicle. RAND National Defense Research Institute, RAND Corporation, California.
- [14] Song, F. and Smith S.M. (2000). Design of Sliding Mode Fuzzy Controllers for an Autonomous Underwater Vehicle without System Mode. MTS/IEEE conference and exhibition, Providence, RI, USA, pp.835-840.
- [15] Gafurov, S.A. and Klochkov, E.V. (2015). Autonomous Unmanned Underwater Vehicles Development Tendencies. Procedia Engineering, Vol.106, pp.141-148.
- [16] Abreu, N. (2010). Automatic Interface for AUV Mission Planning and Supervision. Oceans MTS/IEEE conference, Seattle, WA, USA pp.1-5.
- [17] Roman, C.,Pizarro, O.,Eustice, R. and Singh, H.(2000). A New Autonomous Underwater Vehicle for Imaging Research. Deep Submergence Laboratory, Institute of Electrical and Electronics Engineers, OCEANS 2000 MTS/IEEE Conference and Exhibition, pp.153-156.
- [18] Lin, Y.H., Lin, Y.-T., Chiu, Y.-J. (2021). Stability and Manoeuvrability Simulation of a Semi-Autonomous Submarine Free-Running Model SUBOFF with an Autopilot System. Appl. Sci. 11, 410. <https://doi.org/10.3390/app11010410>.
- [19] Ali, Z.A., Li, X. & Noman, M. (2021). Stabilizing the dynamic behavior and Position control of a Remotely Operated Underwater Vehicle. *Wireless Pers Commun* 116, 1293–1309, <https://doi.org/10.1007/s11277-020-07378-z>.